



Liebherr LTM 1030-2



MAXIMUM
CAPACITY
30T



MAXIMUM
BOOM LENGTH
30M



0474 352 276



www.dlbcranes.com.au

Radius Load Chart

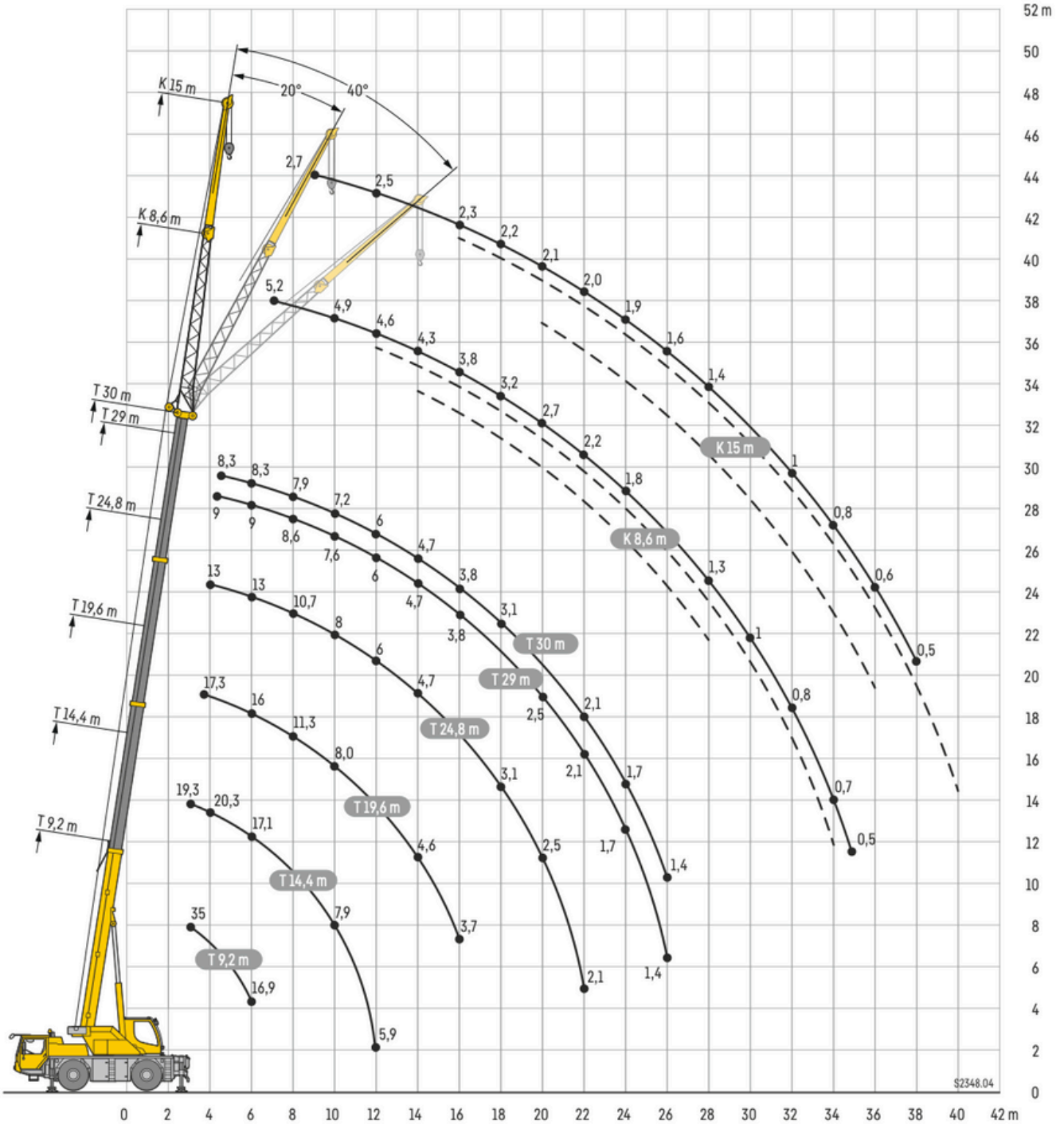

S2348.04



